

ECE 525: Lecture 10

For the CCVT given below

Main Data:

$$V_{LL} := 345\text{kV} \quad V_{\text{sec_nominal}} := 67\text{V} \quad f_{\text{nominal}} := 60\text{Hz}$$

Transformer Data:

$$V_{C2} := 11\text{kV}$$

$$R_P := 300\text{ohm} \quad L_P := 5.6\text{H}$$

$$R_S := 0.034\text{ohm} \quad L_S := 0.0253\text{mH}$$

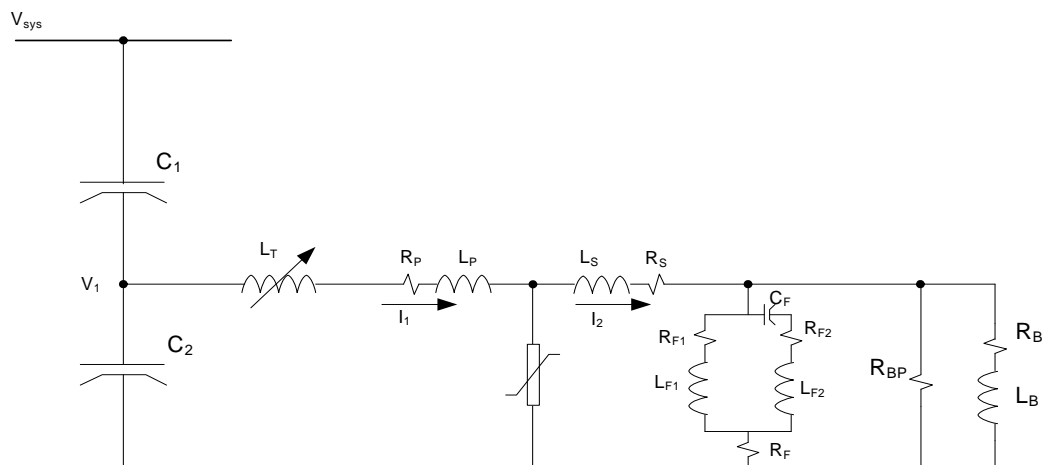

a) Determine the value of C_1 if: $C_2 := 135\text{nF}$

$$\omega := 2 \cdot \pi \cdot 60\text{Hz}$$

The voltage divider is:

$$V_{C2} = \frac{V_{LL}}{\sqrt{3}} \cdot \frac{\frac{1}{\omega \cdot C_2}}{\frac{1}{\omega \cdot C_1} + \frac{1}{\omega \cdot C_2}}$$

Rearranging:

$$\frac{1}{\omega \cdot C_1} + \frac{1}{\omega \cdot C_2} = \frac{V_{LL}}{\sqrt{3} \cdot V_{C2}} \cdot \left(\frac{1}{\omega \cdot C_2} \right)$$

Then:
$$\frac{1}{\omega \cdot C_1} = \left(\frac{1}{\omega \cdot C_2} \right) \cdot \left[\left(\frac{V_{LL}}{\sqrt{3} \cdot V_{C2}} \right) - 1 \right]$$

$$C_1 := \left[\left(\frac{\omega}{\omega \cdot C_2} \right) \cdot \left[\left(\frac{V_{LL}}{\sqrt{3} \cdot V_{C2}} \right) - 1 \right] \right]^{-1} \quad \boxed{C_1 = 7.89 \cdot \text{nF}}$$

As a check:

$$\left(\frac{V_{LL}}{\sqrt{3}} \cdot \frac{\frac{1}{\omega \cdot C_2}}{\frac{1}{\omega \cdot C_1} + \frac{1}{\omega \cdot C_2}} \right) = 11 \cdot \text{kV}$$

b) Determine the tuning inductance, L_T

$$C_{\text{equiv}} := C_1 + C_2$$

$$L_T := \left[\frac{1}{(2 \cdot \pi \cdot f_{\text{nominal}})^2 \cdot C_{\text{equiv}}} - L_p \right] \quad \boxed{L_T = 43.64 \cdot \text{H}}$$

c) Given the following burden and ferro-resonance filter information calculate the magnitude and phase error in the voltage across the burden under steady-state nominal conditions.

Burden

$$R_b := 400.9 \cdot \Omega$$

$$L_b := 1.84 \cdot \text{H}$$

$$R_{bp} := 785 \cdot \Omega$$

Ferroresonance Filter

$$R_{F1} := 1.06 \cdot \Omega$$

$$R_{F2} := 4.24 \cdot \Omega$$

$$C_F := 13.8 \cdot 10^{-6} \cdot \text{F}$$

$$L_{F1} := 0.1 \cdot \text{H}$$

$$L_{F2} := 0.394 \cdot \text{H}$$

$$R_F := 40 \cdot \Omega$$

- The impedance of the ferroresonance filter is somewhat smaller than the burden, so it can't be neglected.

$$f := 0,001\text{Hz}..200\text{Hz} \quad \omega(f) := 2 \cdot \pi \cdot f$$

$$Z_{\text{ferro}}(\omega) := R_F + \left(\frac{1}{R_{F1} + j \cdot \omega \cdot L_{F1}} + \frac{1}{\frac{1}{j \cdot \omega \cdot C_F} + R_{F2} + j \cdot \omega \cdot L_{F2}} \right)^{-1}$$

$$|Z_{\text{ferro}}(2 \cdot \pi \cdot 60\text{Hz})| = 233.65 \Omega$$

$$\arg(Z_{\text{ferro}}(2 \cdot \pi \cdot 60\text{Hz})) = 44.6 \cdot \text{deg}$$

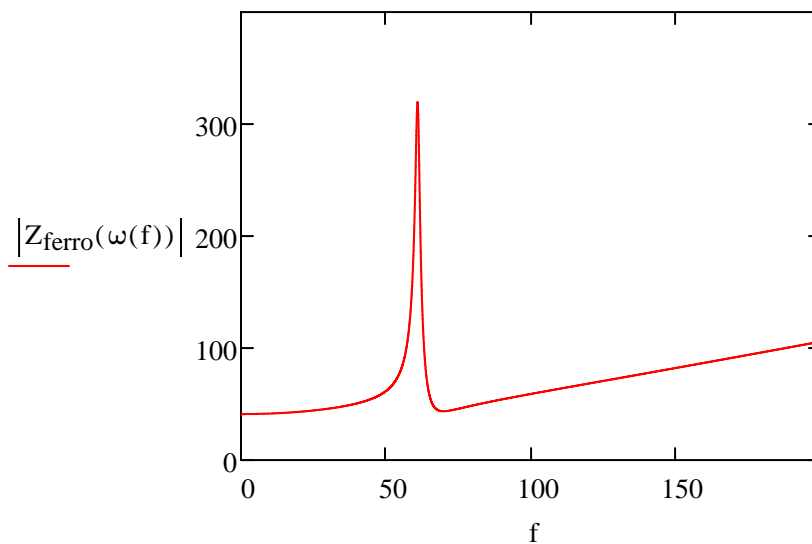

Reset ω

$$\omega := 2 \cdot \pi \cdot 60\text{Hz}$$

- Equivalent burden impedance:

$$Z_{\text{Burden}} := \left(\frac{1}{R_{bp}} + \frac{1}{R_b + j \cdot \omega \cdot L_b} \right)^{-1}$$

$$|Z_{\text{Burden}}| = 457.78 \Omega$$

$$\arg(Z_{\text{Burden}}) = 29.65 \cdot \text{deg}$$

- Parallel Burden with Filter:

$$Z_{\text{para}} := \left(\frac{1}{Z_{\text{ferro}}(\omega)} + \frac{1}{Z_{\text{Burden}}} \right)^{-1}$$

$$|Z_{\text{para}}| = 155.88 \Omega$$

$$\arg(Z_{\text{para}}) = 39.56 \cdot \text{deg}$$

- Secondary winding:

$$Z_{\text{sec_winding}} := R_s + j \cdot \omega \cdot L_s \quad Z_{\text{sec_winding}} = (0.03 + 0.01i) \Omega$$

- Primary impedances:

$$Z_{c1} := \frac{1}{j \cdot \omega \cdot C_1} \quad Z_{c2} := \frac{1}{j \cdot \omega \cdot C_2} \quad Z_T := j \cdot \omega \cdot L_T$$

$$Z_{\text{prim_winding}} := R_p + j \cdot \omega \cdot L_p$$

- Refer primary impedances to secondary: $a := \frac{11\text{kV}}{67\text{V}}$

$$Z'_{c1} := \frac{Z_{c1}}{a^2} \quad Z'_{c1} = -12.47i \Omega \quad Z'_{c2} := \frac{Z_{c2}}{a^2} \quad Z'_{c2} = -0.73i \Omega$$

$$Z'_T := \frac{Z_T}{a^2} \quad Z'_T = 0.61i \Omega \quad Z'_{\text{prim_winding}} := \frac{Z_{\text{prim_winding}}}{a^2}$$

$$Z'_{\text{prim_winding}} = (0.01 + 0.08i) \Omega$$

- Equivalent impedance seen from source, referred to secondary:

$$Z_{\text{equiv_CCVT}} := Z'_{c1} + \left[\frac{1}{Z'_{c2}} + \frac{1}{(Z'_T + Z'_{\text{prim_winding}} + Z_{\text{sec_winding}} + Z_{\text{para}})} \right]^{-1}$$

$$Z_{\text{equiv_CCVT}} = (2.63 \times 10^{-3} - 13.2i) \Omega \quad \text{Entire CCVT as seen from line}$$

- Total current drawn by CCVT from source (secondary amps)-includes both capacitors referred to secondary, so use system voltage not V_{c2}

$$V_{\text{Line_sec}} := \frac{V_{LL}}{a \cdot \sqrt{3}} \quad V_{\text{Line_sec}} = 1213.22 \text{ V}$$

$$I_{\text{total}} := \frac{V_{\text{Line_sec}}}{Z_{\text{equiv_CCVT}}} \quad I_{\text{total}} = (0.02 + 91.9i) \text{ A}$$

- Current Divider between C2 and VT:

$$I_{VT} := I_{total} \cdot \left[\frac{Z'_{c2}}{Z'_{c2} + (Z'_T + Z'_{prim_winding} + Z'_{sec_winding} + Z_{para})} \right]$$

$$|I_{VT}| = 0.43 \text{ A} \quad \arg(I_{VT}) = -39.55 \cdot \text{deg}$$

- Voltage across burden in parallel with ferroresonance filter.

$$V_{burden} := I_{VT} \cdot Z_{para} \quad |V_{burden}| = 66.98 \text{ V} \quad \arg(V_{burden}) = 7.86 \times 10^{-3} \cdot \text{deg}$$

- Error Calculations

$$V_{rated_sec} := \left(\frac{V_{LL}}{\sqrt{3}} \cdot \frac{\frac{1}{\omega \cdot C_2}}{\frac{1}{\omega \cdot C_1} + \frac{1}{\omega \cdot C_2}} \right) \cdot \frac{1}{a} \quad V_{rated_sec} = 67 \text{ V}$$

Magnitude Error:

$$V_{rated_sec} - |V_{burden}| = 0.02 \text{ V}$$

Percent Magnitude Error:

$$\frac{V_{rated_sec} - |V_{burden}|}{V_{rated_sec}} = 0.0262 \cdot \%$$

- Since reference voltage is at 0 degrees

$$\text{Angle_error} := \arg(V_{burden}) \quad \text{Angle_error} = 0.01 \cdot \text{deg}$$

Define units for angle smaller than degree

$$\text{arcmin} := \frac{\text{deg}}{60} \quad \text{Angle_error} = 0.47 \cdot \text{arcmin} \quad \text{in minutes of arc}$$

$$\text{arcsec} := \frac{\text{arcmin}}{60} \quad \text{Angle_error} = 28.3 \cdot \text{arcsec} \quad \text{in seconds of arc}$$