

ECE 525: Homework #4

Due Session 20 (Oct. 25)

For the power system below, do the following, and *verify proper coordination for each*:

- Determine phase element relay settings for feeder relay (B3) and reclosers (R1 and R2). Coordinate settings between the protective devices for phase faults (phase to phase and 3 phase) and with the transformer damage curve. Include an instantaneous element for B3 to improve response time. You should determine the CTR and the select the TOC curve type.
- Determine ground element relay settings for feeder relay (B3) and reclosers (R1 and R2). Coordinate settings between the protective devices for ground faults (SLG) and with the transformer damage curve.
- Determine phase element relay settings for transformer HV side relay (B2) and line relay (B1). Ensure effective coordination between these protective devices. The transformer protection (B2) needs to coordinate with B3. Assume rated load on transformer is 40MVA at unity power factor (note it supplies multiple feeders)

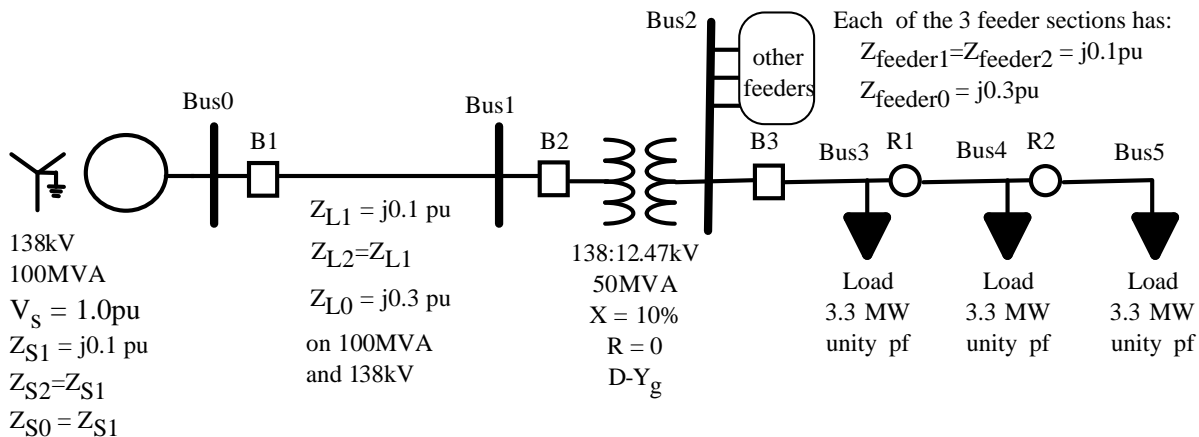

Assume the following:

- Set the coordinating time interval at 6 cycles for each device (relay/recloser control)
- The worst case zero sequence imbalance for each load current on the distribution feeder is 20% ($3 \cdot I_0$)
- The transformer follows the ANSI/IEEE standard phase shift
- The fault currents by location and fault type are as follows (note that you will need refer currents across the transformer for some coordination cases. The fault currents by fault type and fault location are as follow.

| Three Phase Fault | Bus 1 | | Bus 2 | | Bus 3 | | Bus 4 | | Bus 5 | |
|--------------------|---------|------|---------|------|--------|------|--------|------|--------|------|
| IA (Mag and angle) | 2091.85 | -90 | 11575 | -90 | 9259.8 | -90 | 7761.5 | -90 | 6614.2 | -90 |
| IB (Mag and angle) | 2091.85 | -210 | 11575 | -210 | 9259.8 | -210 | 7761.5 | -210 | 6614.2 | -210 |
| IC (Mag and angle) | 2091.85 | 30 | 11575 | 30 | 9259.8 | 30 | 7761.5 | 30 | 6614.2 | 30 |
| SLG Fault | Bus 1 | | Bus 2 | | Bus 3 | | Bus 4 | | Bus 5 | |
| IA (Mag and angle) | 1568.9 | -90 | 13889.7 | -90 | 9259.8 | -90 | 6944.9 | -90 | 5555.9 | -90 |
| IB (Mag and angle) | 0 | 0 | 0 | 0 | 0 | 0 | 0 | 0 | 0 | 0 |
| IC (Mag and angle) | 0 | 0 | 0 | 0 | 0 | 0 | 0 | 0 | 0 | 0 |
| LL Fault | Bus 1 | | Bus 2 | | Bus 3 | | Bus 4 | | Bus 5 | |
| IA (Mag and angle) | 0 | 0 | 0 | 0 | 0 | 0 | 0 | 0 | 0 | 0 |
| IB (Mag and angle) | 1811.6 | 180 | 10024.1 | 180 | 8019.3 | 180 | 6682.7 | 180 | 5728 | 180 |
| IC (Mag and angle) | 1811.6 | 0 | 10024.1 | 0 | 8019.3 | 0 | 6682.7 | 0 | 5728 | 0 |

- Possible Relay Inverse Time Overcurrent Curves:

- All are in the format: $t_m = TD \cdot \left(\frac{A}{M^P - 1} + B \right)$ where A, B and P come from US curves U1-U4 (listed in the lecture 14 handout)

- Moderately inverse (U1):

$$t_{MI}(TD, M) := TD \cdot \left(\frac{0.0104}{M^{0.02} - 1} + 0.2256 \right) \cdot \text{sec}$$

- Inverse (U2):

$$t_I(TD, M) := TD \cdot \left(\frac{5.95}{M^2 - 1} + 0.180 \right) \cdot \text{sec}$$

- Very inverse (U3):

$$t_{VI}(TD, M) := TD \cdot \left(\frac{3.88}{M^2 - 1} + 0.0963 \right) \cdot \text{sec}$$

- Extremely inverse (U4):

$$t_{EI}(TD, M) := TD \cdot \left(\frac{5.67}{M^2 - 1} + 0.0352 \right) \cdot \text{sec} \quad M := 1, 1.5 \dots 50$$

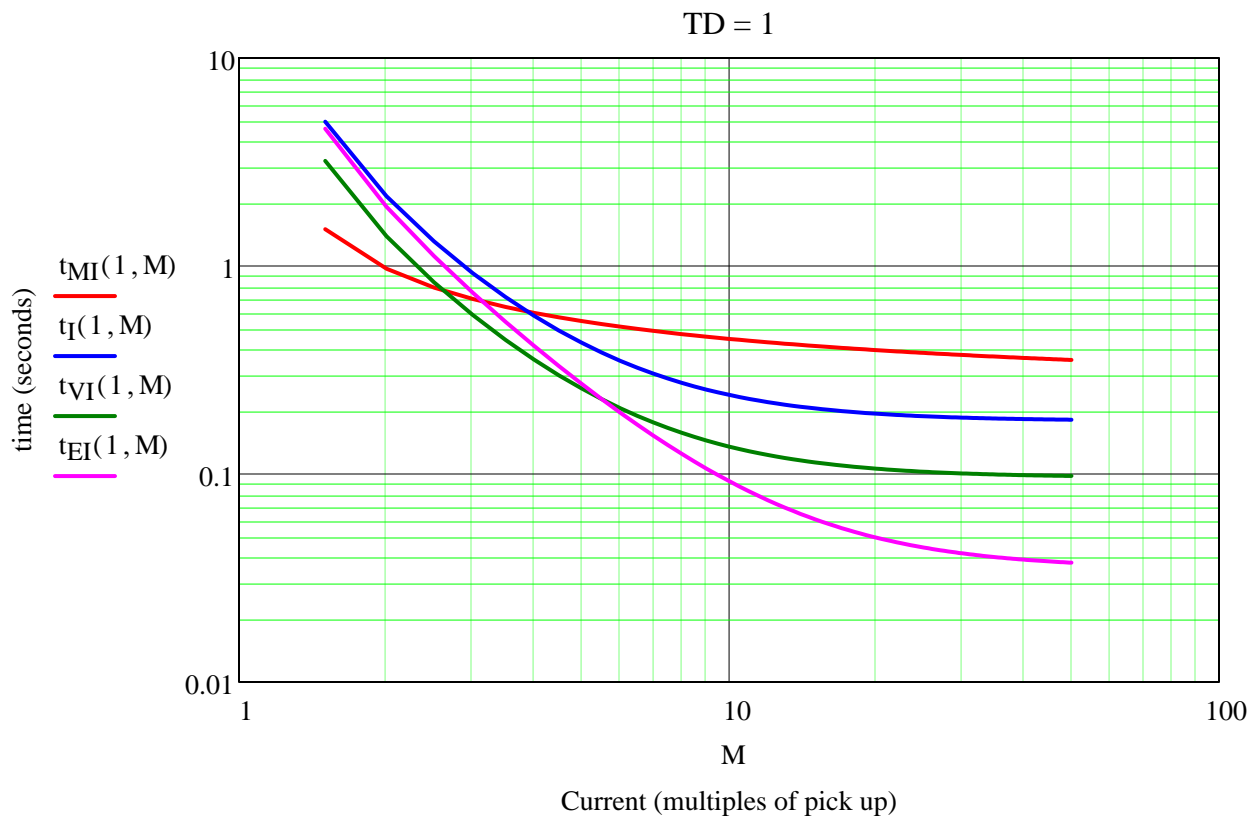

- Transformer Damage Curve
(where M is multiples of
rated current):

$$\text{Mult}_{\text{xfmr}} := \begin{pmatrix} 2.00 \\ 3.00 \\ 4.00 \\ 5.00 \\ 5.00 \\ 10.00 \end{pmatrix} \quad \text{T}_{\text{lim}} := \begin{pmatrix} 1800.0 \\ 300.0 \\ 100.0 \\ 50.0 \\ 8.0 \\ 2.0 \end{pmatrix} \text{ sec}$$

