

ECE 320
Energy Systems I
Sample Exam #2

- 1 _____ / 30 pts
2 _____ / 12 pts
3 _____ / 30 pts
4 _____ / 28 pts
Total _____ / 100 pts

1. (30 pts) A 230V, shunt excited DC motor has $R_A = 0.05\Omega$ and $R_f = 75\Omega$. The motor draws a line current, I_L , of 7 A when lightly loaded and turning at 1120 RPM. With the machine loaded such that the line current is 46 A, answer the following. Assume the iron is linear (i.e. no saturation in E_A vs. I_f curve).

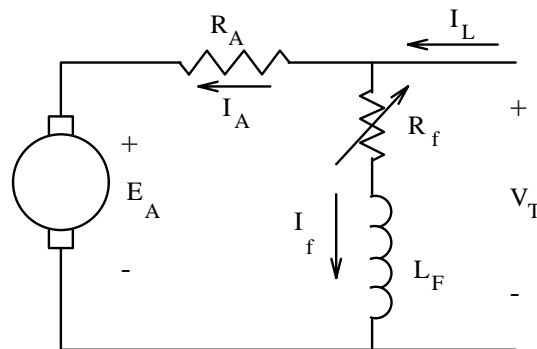

- A Find speed in RPM
- B Find induced torque.
- C Suppose the field current is increased to 100Ω , find the speed if the line current stays at 46 A.
- D If the machine experiences armature reaction, how would this impact the torque speed characteristic? Explain and sketch an approximate characteristic.

2. (12 pts) A cumulatively compounded generator with interpoles (to correct armature reaction) is to be used as a compounded motor. If no changes are made to the internal connections, will the motor be cumulatively compounded or differentially compounded? Explain.

Will the polarity on the interpoles be correct? Explain why or why not.

Will the direction of rotation be the same as or opposite to the direction in which it was driven as a generator?

3. (30 pts)

Short Answer (5 points each). Write your answers on a separate sheet of paper.

A. How does a dc generator with a shunt field produce the induced voltage, E_a when it is first started up?

Are there any pitfalls with this technique? How are they resolved?

B. What is armature reaction? How does it impact the output of a dc generator?

C. A diesel engine is used to turn the rotor on a dc generator. If the operator increases the rotor speed what happens to the output voltage? Explain.

D. What are the mechanisms that cause no-load losses to occur in a separately excited dc motor (with the field energized)? Are there additional losses under load? What causes these additional losses?

E. What happens to a shunt field dc motor when the field current is interrupted? Why? Is this a problem with a series field motor, why or why not?

F. Is torque induced on the rotor of a dc generator when it supplies an electrical load? Explain? If there is torque induced, how does it relate to the mechanical torque applied by the prime mover?

4. (28 pts) The open circuit characteristic for a 6 pole dc generator rated at 500 V and 500 kW is given below. The characteristic was measured at a speed of 1000 RPM. $R_A=0.02 \Omega$ (counting brush drop).

I_f, A	0	1	2	3	4	5	6	6.5	7	7.5	8
$V_T=E_A, V$	10	100	200	300	390	450	490	500	510	520	525

- A** Calculate the shunt resistance ($R_F + R_{adj}$) required to produce rated terminal voltage when the machine is unloaded.
- B** Using the shunt resistance calculated in part **A**, calculate the terminal voltage when the armature current is 1000A and the speed is 1000 RPM (ignore armature reaction).
- C** Why does the magnetization curve given with this problem flatten out as the field current is increased? How would the curve differ if calculated at a different rotor speed?